

Isolation RS-232/422/485 MIO-E Design Reference

Revision 1.0

Reference Documents

Document	Location
SCH3106 Datasheet	
SP339 Datasheet	

Introduction

- This document is the design reference for designing a MIOe module with isolation RS-232/422/485 feature to work with Advantech MIO single board.

- Contents:
 - Function Selection Table
 - PCB Layout Considerations
 - Reference Schematic
 - Component List

This document is only for MIOe design reference purpose only. Although the information is intended to be accurate, Advantech makes no claims, promises, or guarantees about the quality or reliability of a MIOe board that designed by any user who is outside of Advantech Corp.

FUNCTION SELECTION TABLE

SYSOPT0, SYSOPT1 (Pin U3.68, U3.70):

Configuration	Base I/O address
1. Pull-up SYSOPT0 with a 10 K Ω resistor to 3.3V power rail. 2. Pull-up SYSOPT1 with a 10 K Ω resistor to 3.3V power rail.	0x04E

MODE0, MODE 1 (Pin U5.14, U5.15):

Configuration	Function
MODE0 = Logic High & MODE1 = Logic Low	RS-232
MODE0 = Logic Low & MODE1 = Logic High	RS-485
MODE0 = Logic High & MODE1 = Logic High	RS-422

PCB Layout Considerations

Please notice that PCB Layout will be vary depends on design. For layout considerations, please refer to SCH3106 and SP339 datasheet.

Reference Schematic

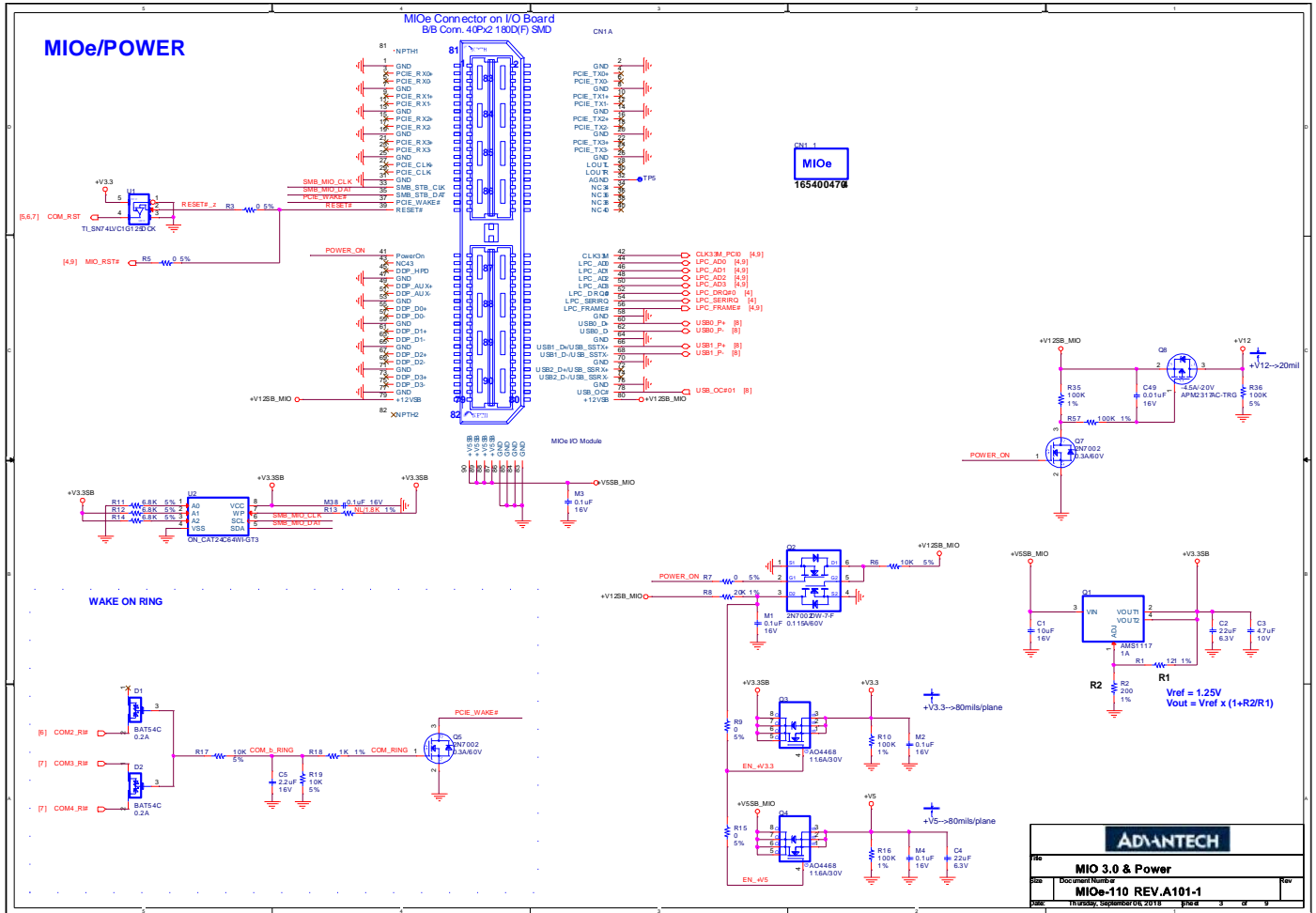

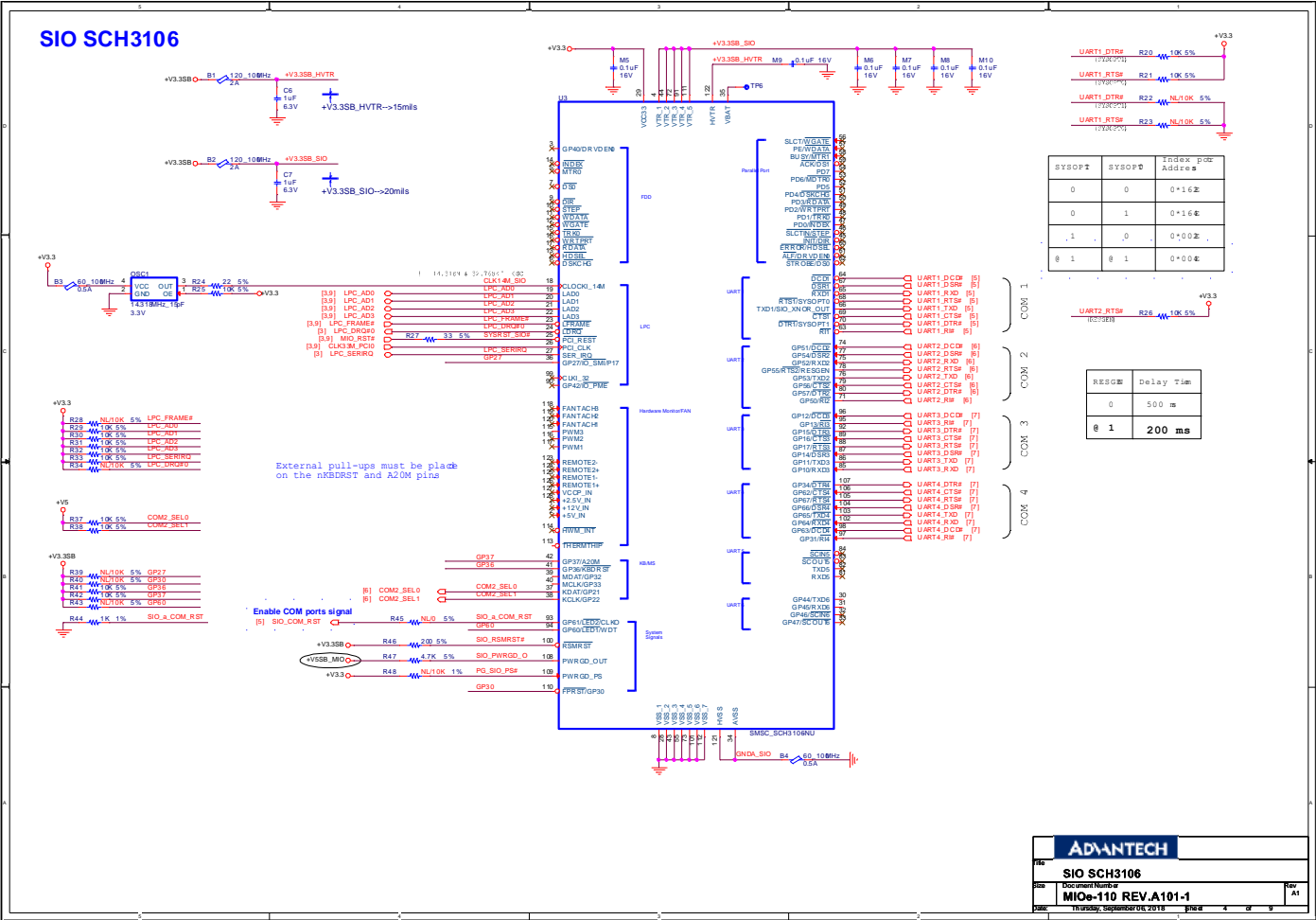

ADVANTECH

SIO SCH3106

MIOe-110 REV.A101-1

MIOe-110 Rev. A101-1

COM1

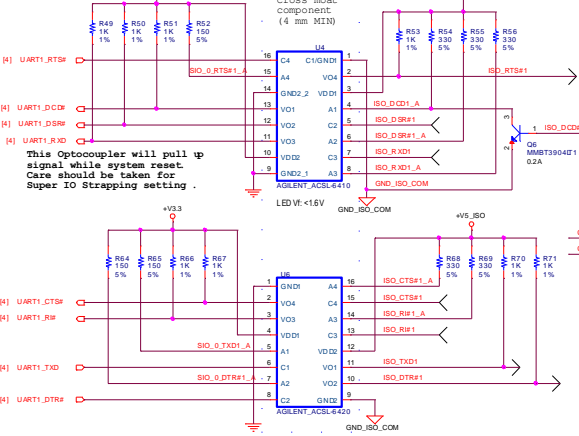

This Optocoupler will pull up signal while system reset. Care should be taken for Super IO Strapping setting.

	1	2	3	4
Loopback mode	OFF	ON	OFF	ON
RS-232 mode	ON	OFF	OFF	ON
RS-485 2W	OFF	ON	ON	OFF
RS-422&RS-485 4W	ON	OFF	ON	OFF

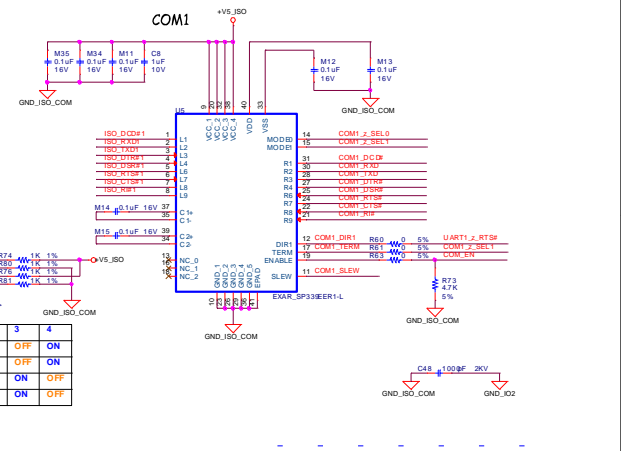

Anti-Etch all copper layers after Optocoupler/ISO. PWR (Between Optocoupler/ISO, PWR to COM Port) NEED 4mm CLEARANCE.

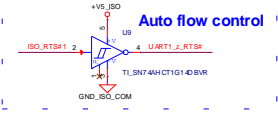
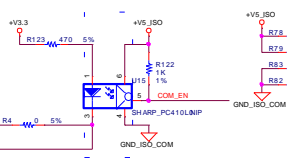

Model/Mode0	00	01	10	11
Loopback mode	V			
RS-232 mode		V		
RS-485 2W			V	
RS-422&RS-485 4W				V
SLEW		SLEW = VCC enables 250Mbps slew limiting		
DIR1		Y1 Enable, Y1 Disable		Y1 Enable
TERM		Enable RS-485/422 receive termination		

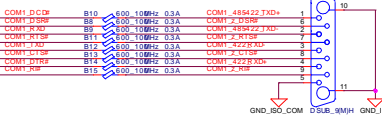
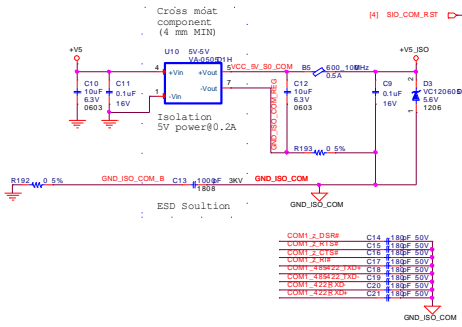

COM1

Document Number: MIOe-110 REV.A101-1

Date: 11/05/2019, Update Rev: 2019 Date: 5 of 9

Component List

QTY	Description	Reference	Manufacture Part Number	Manufacture
1	CR 20K 1% 1/16W SMD 0402	R8	0402WGF2002TCE	厚聲電子工業有限公司 (Uniroyal Electronics Industry Co.,Ltd.)
1	CR 1.8K 1% 1/16W SMD 0402	R13	0402WGF1801TCE	厚聲電子工業有限公司 (Uniroyal Electronics Industry Co.,Ltd.)
1	MLCC X5R 1uF ±10% 10V SMD 0402	C8	0402X105K100CT	台灣東電化股份有限公司 (TDK Taiwan Corporation)
2	MLCC X5R 22uF 20% 6.3V SMD 0805	C2	0805X226M6R3CT	台灣村田股份有限公司 (Taiwan Murata Electronics Co., Ltd.)
		C4		
20	MLCC X7R 0.1uF 10% 16V SMD 0402	C9	0402B104K160CT	國巨股份有限公司 (Yageo Co.,Ltd.)
		C11		
		M1		
		M2		
		M3		
		M4		
		M5		
		M6		
		M7		
		M8		
		M9		
		M10		
		M11		
		M12		
		M13		
M14				
M15				
M34				
M35				
M38				
2	MLCC X5R 1uF 10% 6.3V SMD 0402	C6	0402X105K6R3CT	台灣東電化股份有限公司 (TDK Taiwan Corporation)
		C7		

Enabling an Intelligent Planet

1	MLCC X7R 0.01uF 10% 16V SMD 0402	C49	0402B103K160CT	國巨股份有限公司 (Yageo Co.,Ltd.)
8	MLCC X7R 180pF 10% 50V SMD 0402	C14	CC0402KRX7R9BB181	國巨股份有限公司 (Yageo Co.,Ltd.)
		C15		
		C16		
		C17		
		C18		
		C19		
		C20		
1	MLCC X7R 1000pF 20% 2kV SMD 1206	C48	12062R102M202BL	澤天科技股份有限公司 (SKYWELL TECHNOLOGY)
1	MLCC Y5V 4.7uF +80%-20% 10V SMD 0805	C3	C0805Y475Z010T	台灣太陽誘電(股)公司 (Taiwan Taiyo Yuden Co., Ltd.)
2	Bead 120ohm 25% 2A SMD 0603 BLM18PG121SN1	B1	BLM18PG121SN1	台灣村田股份有限公司 (Taiwan Murata Electronics Co., Ltd.)
		B2		
1	Bead 600ohm 25% 0.5A SMD 0603 BLM18EG601SN1	B5	BLM18EG601SN1	台灣村田股份有限公司 (Taiwan Murata Electronics Co., Ltd.)
2	Bead 60ohm 500mA SMD 0603 BLM18PG600SN1D	B3	BLM18PG600SN1D	台灣村田股份有限公司 (Taiwan Murata Electronics Co., Ltd.)
		B4		
8	Bead 600ohm 25% 300mA SMD 0402	B8	BLM15AG601SN1D	台灣村田股份有限公司 (Taiwan Murata Electronics Co., Ltd.)
	Bead 600ohm 25% 300mA SMD 0402	B9		
	Bead 600ohm 25% 300mA SMD 0402	B10		
	Bead 600ohm 25% 300mA SMD 0402	B11		
	Bead 600ohm 25% 300mA SMD 0402	B12		
	Bead 600ohm 25% 300mA SMD 0402	B13		
	Bead 600ohm 25% 300mA SMD 0402	B14		
Bead 600ohm 25% 300mA SMD 0402	B15			

Enabling an Intelligent Planet

2	MLCC X5R 10uF 20% 6.3V SMD 0603	C10	C0603B106M007T	台灣東電化股份有限公司 (TDK Taiwan Corporation)
		C12		
1	MLCC X7R 2.2uF 10% 16V SMD 0805	C5	0805B225K160CT	台灣東電化股份有限公司 (TDK Taiwan Corporation)
1	MLCC X7R 10uF 10% 16V SMD 1206	C1	C1206X106K016T	台灣東電化股份有限公司 (TDK Taiwan Corporation)
1	MLCC NPO 1000pF 10% 3kV SMD 1808	C13	C1808N102K302T	NOVACAP INC.
1	OSC 14.318MHZ 50ppm 3.3V 15pF SMD 4P 7x5mm	OSC1	7W14300014	台灣晶技股份有限公司 (Txc Corporation)
1	Converter DC-DC 5V-5V 200mA VA-0505D1H	U10	VA-0505D1H	模甸科技股份有限公司 (Motien Technology Co., Ltd.)
2	Schottky BAT54C 0.2A 30V SMD SOT-23	D1	BAT54C	恩智浦半導體 (NXP Semiconductors)
		D2		
1	TVS VC120605D150RP 5.6V SMD 1206	D3	VC120605D150RP	香港商安施有限公司 (Avx/Kyocera H.K. Ltd.)
2	MOSFET N-CH AO4468 11.6A 30V SMD SOIC8 8P	Q3	AO4468	香港商萬國半導體股份有限公司 (Alpha & Omega Semiconductor Ltd.)
		Q4		
2	MOSFET N-CH 2N7002 0.3A 60V SMD SOT-23 3P	Q5	2N7002	恩智浦半導體 (NXP Semiconductors)
		Q7		
1	MOSFET P-CH APM2317AC-TRG -20V -4.5A SMD SOT-23	Q8	APM2317AC-TRG	大中積體電路股份有限公司 (Sinopower Semiconductor Inc.)
1	TRANS NPN MMBT3904LT1G 0.2A SMD SOT-23 3P	Q6	MMBT3904LT1G	安森美半導體 (On Semiconductor)
1	MOSFET N-CH 2N7002DW-7-F 0.115A 60V SMT SOT-363	Q2	2N7002DW-7-F	Diodes Inc.
1	CR 10K 1% 1/16W SMD 0402	R48	0402WGF1002TCE	厚聲電子工業有限公司 (Uniroyal Electronics Industry Co.,Ltd.)
4	CR 100K 1% 1/16W SMD 0402	R10	0402WGF1003TCE	厚聲電子工業有限公司 (Uniroyal Electronics Industry Co.,Ltd.)
		R16		
		R35		
		R57		
1	CR 121 1% 1/10W SMD 0603	R1	0603WAF1210T5E	厚聲電子工業有限公司 (Uniroyal Electronics Industry Co.,Ltd.)
3	CR 150 5% 1/16W SMD 0402	R52	0402WGJ0151TCE	厚聲電子工業有限公司 (Uniroyal Electronics Industry Co.,Ltd.)
		R64		
		R65		

Enabling an Intelligent Planet

1	CR 100K 5% 1/16W SMD 0402	R36	0402WGJ0104TCE	厚聲電子工業有限公司 (Uniroyal Electronics Industry Co.,Ltd.)
19	CR 1K 1% 1/16W SMD 0402	R18	0402WGF1001TCE	厚聲電子工業有限公司 (Uniroyal Electronics Industry Co.,Ltd.)
		R44		
		R49		
		R50		
		R51		
		R53		
		R66		
		R67		
		R70		
		R71		
		R74		
		R76		
		R78		
		R79		
R80				
R81				
R82				
R83				
R122				
1	CR 200 1% 1/10W SMD 0603	R2	0603WAF2000T5E	厚聲電子工業有限公司 (Uniroyal Electronics Industry Co.,Ltd.)
10	CR 0 5% 1/16W SMD 0402	R3	0402WGJ0000TCE	厚聲電子工業有限公司 (Uniroyal Electronics Industry Co.,Ltd.)
		R4		
		R5		
		R7		
		R9		
		R15		
		R45		
		R60		
		R61		
		R63		
2	CR 0 5% 1/10W SMD 0603	R192	0603WAJ0000T5E	厚聲電子工業有限公司 (Uniroyal Electronics Industry Co.,Ltd.)
		R193		

Enabling an Intelligent Planet

23	CR 10K 5% 1/16W SMD 0402	R6	0402WGJ0103TCE	厚聲電子工業有限公司 (Uniroyal Electronics Industry Co.,Ltd.)
		R17		
		R19		
		R20		
		R21		
		R22		
		R23		
		R25		
		R26		
		R28		
		R29		
		R30		
		R31		
		R32		
		R33		
		R34		
R37				
R38				
R39				
R40				
R41				
R42				
R43				
1	CR 200 5% 1/16W SMD 0402	R46	0402WGJ0201TCE	厚聲電子工業有限公司 (Uniroyal Electronics Industry Co.,Ltd.)
1	CR 22 5% 1/16W SMD 0402	R24	0402WGJ0220TCE	厚聲電子工業有限公司 (Uniroyal Electronics Industry Co.,Ltd.)
6	CR 330 5% 1/16W SMD 0402	R54	0402WGJ0331TCE	厚聲電子工業有限公司 (Uniroyal Electronics Industry Co.,Ltd.)
		R55		
		R56		
		R58		
		R68		
R69				
1	CR 33 5% 1/16W SMD 0402	R27	0402WGJ0330TCE	厚聲電子工業有限公司 (Uniroyal Electronics Industry Co.,Ltd.)
1	CR 470 5% 1/10W SMD 0603	R123	0603WAJ0471T5E	厚聲電子工業有限公司 (Uniroyal Electronics Industry Co.,Ltd.)

Enabling an Intelligent Planet

2	CR 4.7K 5% 1/16W SMD 0402	R47	0402WGJ0472TCE	厚聲電子工業有限公司 (Uniroyal Electronics Industry Co.,Ltd.)
		R73		
3	CR 6.8K 5% 1/16W SMD 0402	R11	0402WGJ0682TCE	厚聲電子工業有限公司 (Uniroyal Electronics Industry Co.,Ltd.)
		R12		
		R14		
1	REG LDO AMS1117 SMD SOT-223 3P 1A ADJ AMS	Q1	AMS1117	Advanced Monolithic System Inc.
1	IC SN74AHCT1G14DBVR Logic Gate TTL SMD SOT-23 5P	U9	SN74AHCT1G14DBVR	德州儀器工業股份有限公司 (Texas Instruments Incorporated)
1	IC PC410L0NIP0F OPTOCOUPLER SMD Mini-flat 5P	U15	PC410L0NIP0F	夏普光電股份有限公司 (Sharp Corporation)
1	IC SN74LVC1G125DCKR SMD SC-70 5P	U1	SN74LVC1G125DCKJ	德州儀器工業股份有限公司 (Texas Instruments Incorporated)
1	IC SMD ACSL-6410-50TE SOIC 16P Optocoupler	U4	ACSL-6410-50TE	安華高科技股份有限公司 (Avago Technologies International Sales Pte.Limited.)
1	IC SMD ACSL-6420-50TE SOIC 16P Optocoupler	U6	ACSL-6420-50TE	安華高科技股份有限公司 (Avago Technologies International Sales Pte.Limited.)
1	IC SCH3106-NU SMD VTQFP 128P	U3	SCH3106-NU	美商史恩希股份有限公司 (Standard Microsystems Corporation)
1	IC CAT24C64WI-GT3 EEPROM SMD SOIC 8P	U2	CAT24C64WI-GT3	安森美半導體 (On Semiconductor)
1	IC SP339EER1-L Transceiver SMD TQFN 40P	U5	SP339EER1-L/TR	美商艾科嘉公司 (Exar Corporation)
1	DIP SW SMD 8P SPST P=1.27mm W=5.4mm KHS42E	SW1	CHS-04TB(29)	中國電子器材深圳有限公司
1	BOX HEADER 5x2P 2.00mm 180D(M) SMD 23N685B-10M10	CN2	23N685B-10M10B -01G-7.6-C	致威電子公司 (Jih Vei Electronics Co., Ltd.)
1	MIOE Connector	CN1	QTE-040-05-L-D-A	Samtec U.S.A.
1	D-SUB Conn. 9P 5mm 90D(M)	CN3	070205MR009S202BA	實盈股份有限公司 (Suyin Corporation)

Other Remarks

This document provides a reference on hardware design only. For other support or resource such as Firmware or other utilities, please contact your local agent.