

Board Diagram

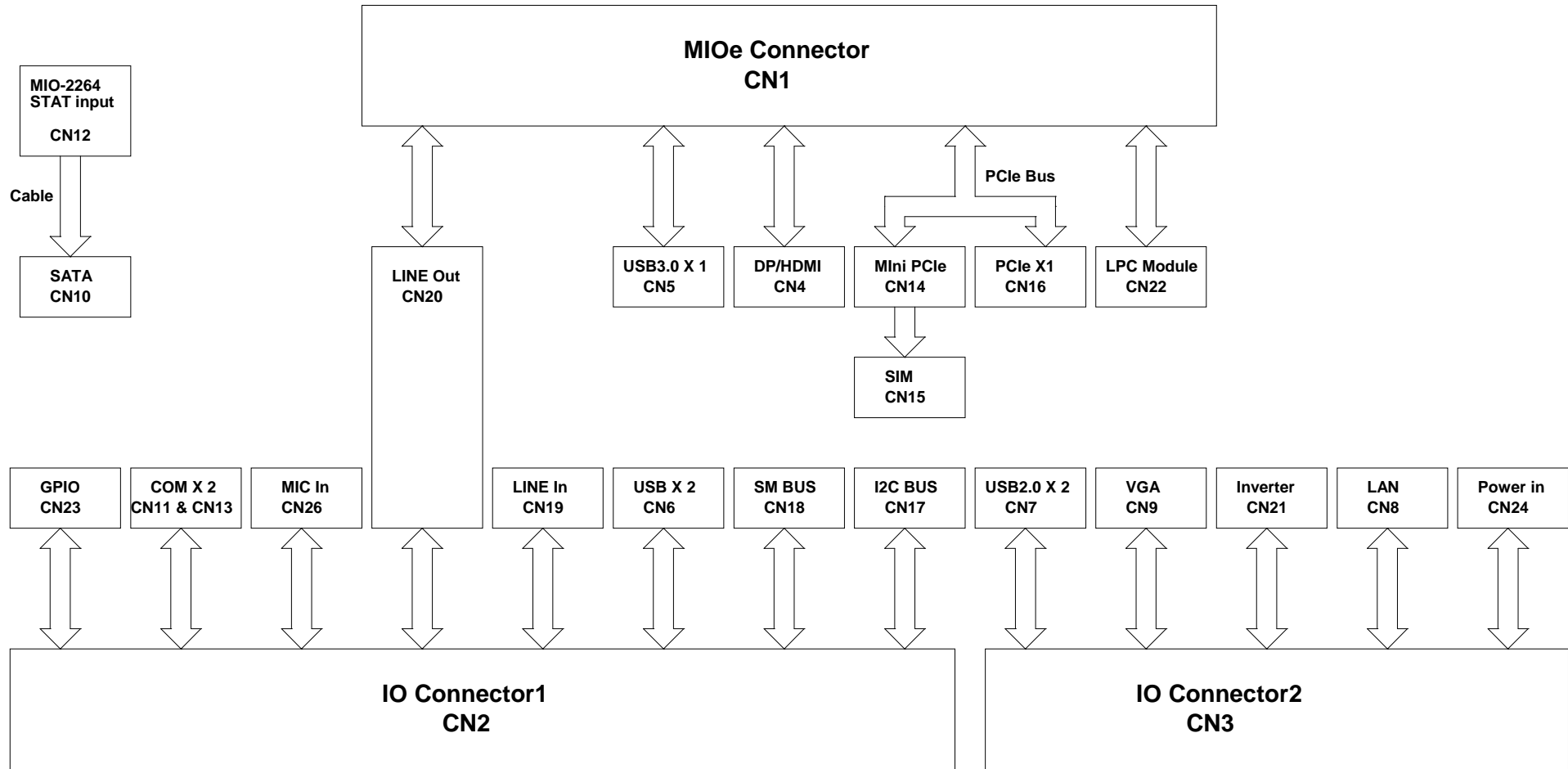

<IP Number>		ADANTECH	
Title			
Block Diagram			
Size	Customer	Document Number	Rev
		MIOe-DB2100 A101-2	A1
Date:	Monday, March 30, 2015		Sheet 1 of 10

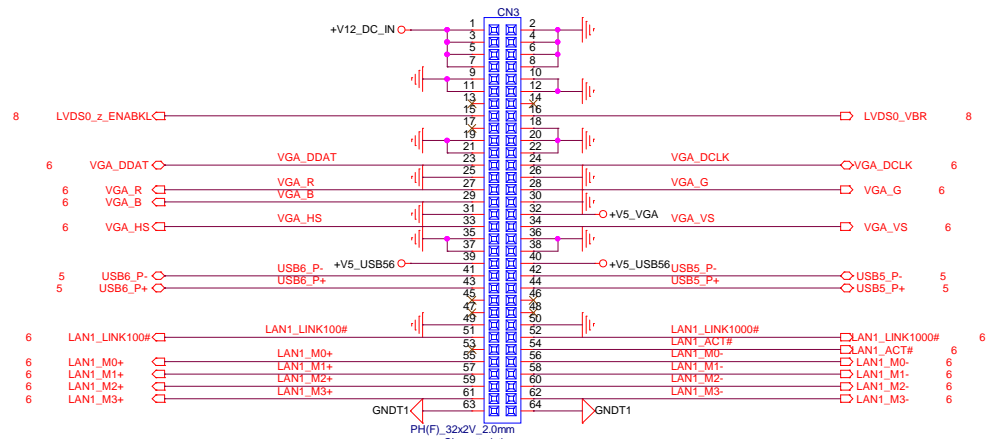
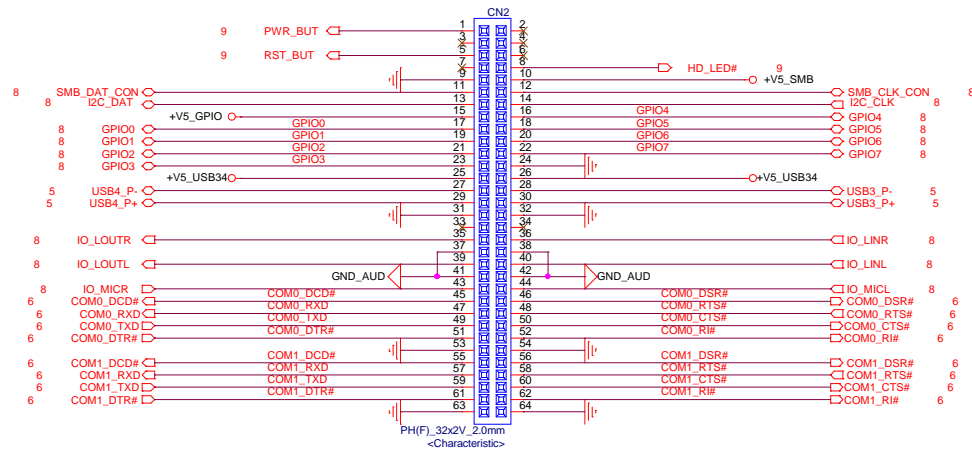

DP + HDMI

2	DPC_HDMI_TX0+	CS1	0.1uF	0402	DPC_HDMI_z_TX0+
2	DPC_HDMI_TX0-	CS2	0.1uF	0402	DPC_HDMI_z_TX0-
2	DPC_HDMI_TX1+	CS3	0.1uF	0402	DPC_HDMI_z_TX1+
2	DPC_HDMI_TX1-	CS4	0.1uF	0402	DPC_HDMI_z_TX1-
2	DPC_HDMI_TX2+	CS5	0.1uF	0402	DPC_HDMI_z_TX2+
2	DPC_HDMI_TX2-	CS6	0.1uF	0402	DPC_HDMI_z_TX2-
2	DPC_HDMI_TX3+	CS7	0.1uF	0402	DPC_HDMI_z_TX3+
2	DPC_HDMI_TX3-	CS8	0.1uF	0402	DPC_HDMI_z_TX3-

R14	NL/499	1%	0402	DPC_HDMI_z_TX0+
R15	NL/499	1%	0402	DPC_HDMI_z_TX0-
R16	NL/499	1%	0402	DPC_HDMI_z_TX1+
R17	NL/499	1%	0402	DPC_HDMI_z_TX1-
R18	NL/499	1%	0402	DPC_HDMI_z_TX2+
R19	NL/499	1%	0402	DPC_HDMI_z_TX2-
R20	NL/499	1%	0402	DPC_HDMI_z_TX3+
R21	NL/499	1%	0402	DPC_HDMI_z_TX3-

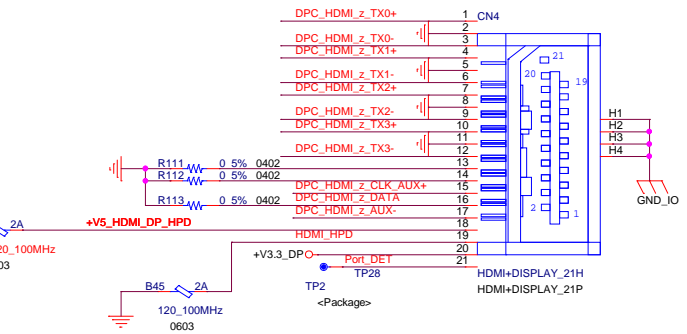
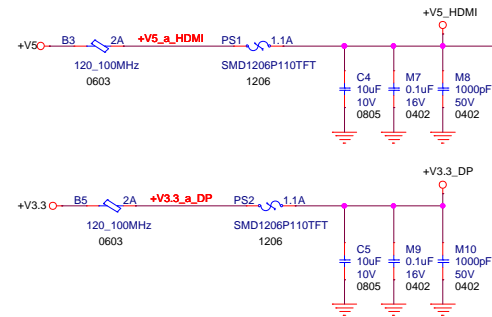

DP0/1 DP TO TMDS MAPPING

DP_TXP0 -> TMDS_TX2P
 DP_TXN0 -> TMDS_TX2N
 DP_TXP1 -> TMDS_TX1P
 DP_TXN1 -> TMDS_TX1N
 DP_TXP2 -> TMDS_TX0P
 DP_TXN2 -> TMDS_TX0N
 DP_TXP3 -> TMDS_CLKP
 DP_TXN3 -> TMDS_CLKN

AUXP -> DDC_CLK
 AUXN -> DDC_DATA

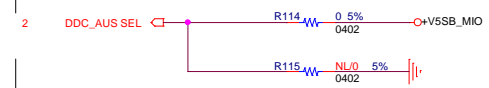
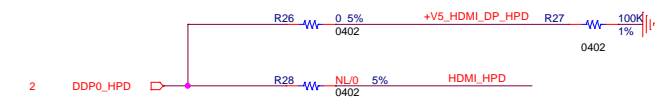
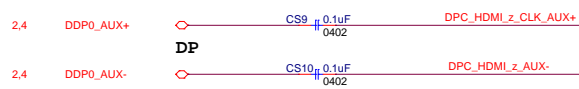
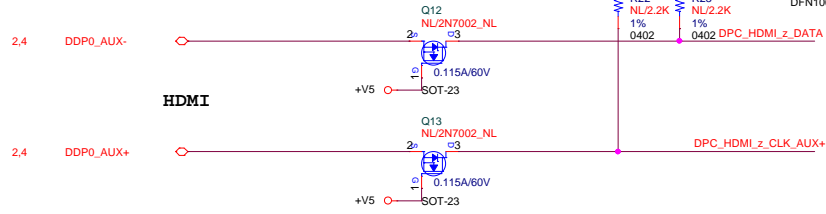

DDIO Port DDC/AUX SEL
 R114 : ADS
 R115 : DDC

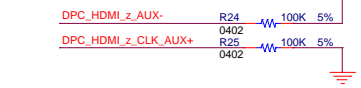
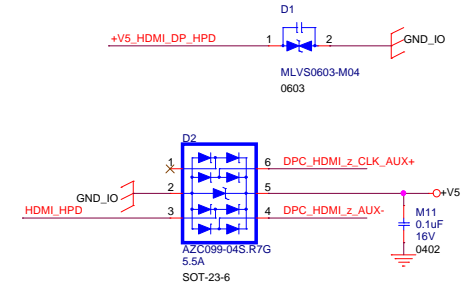

HDMI		DISPLAYPORT	
PIN	SIGNAL NAME	PIN	SIGNAL NAME
1	TMDS Data2+	1	ML_LANE 0(p)
2	TMDS Data2 Shield	2	GND
3	TMDS Data2-	3	ML_LANE 0(n)
4	TMDS Data1+	4	ML_LANE 1(p)
5	TMDS Data1 Shield	5	GND
6	TMDS Data1-	6	ML_LANE 1(n)
7	TMDS Data0+	7	ML_LANE 2(p)
8	TMDS Data0 Shield	8	GND
9	TMDS Data0-	9	ML_LANE 2(n)
10	TMDS Clock+	10	ML_LANE 3(p)
11	TMDS Clock Shield	11	GND
12	TMDS Clock-	12	ML_LANE 3(n)
13	CEC	13	GND
14	RESERVED (in cable but NC on device)	14	GND
15	SCL	15	AUX_CH (p)
16	SDA	16	GND
17	DDC/CEC GROUND	17	AUX_CH (n)
18	+5V Power	18	Hot Plug Detect
19	Hot Plug Detect	19	Return
20		20	DP_PWR

ADANTECH

Title: **HDMI/Display port**

Size: MIOe-DB2100 A101-2

Document Number: MIOe-DB2100 A101-2

Date: Monday, March 30, 2015

Sheet 4 of 10

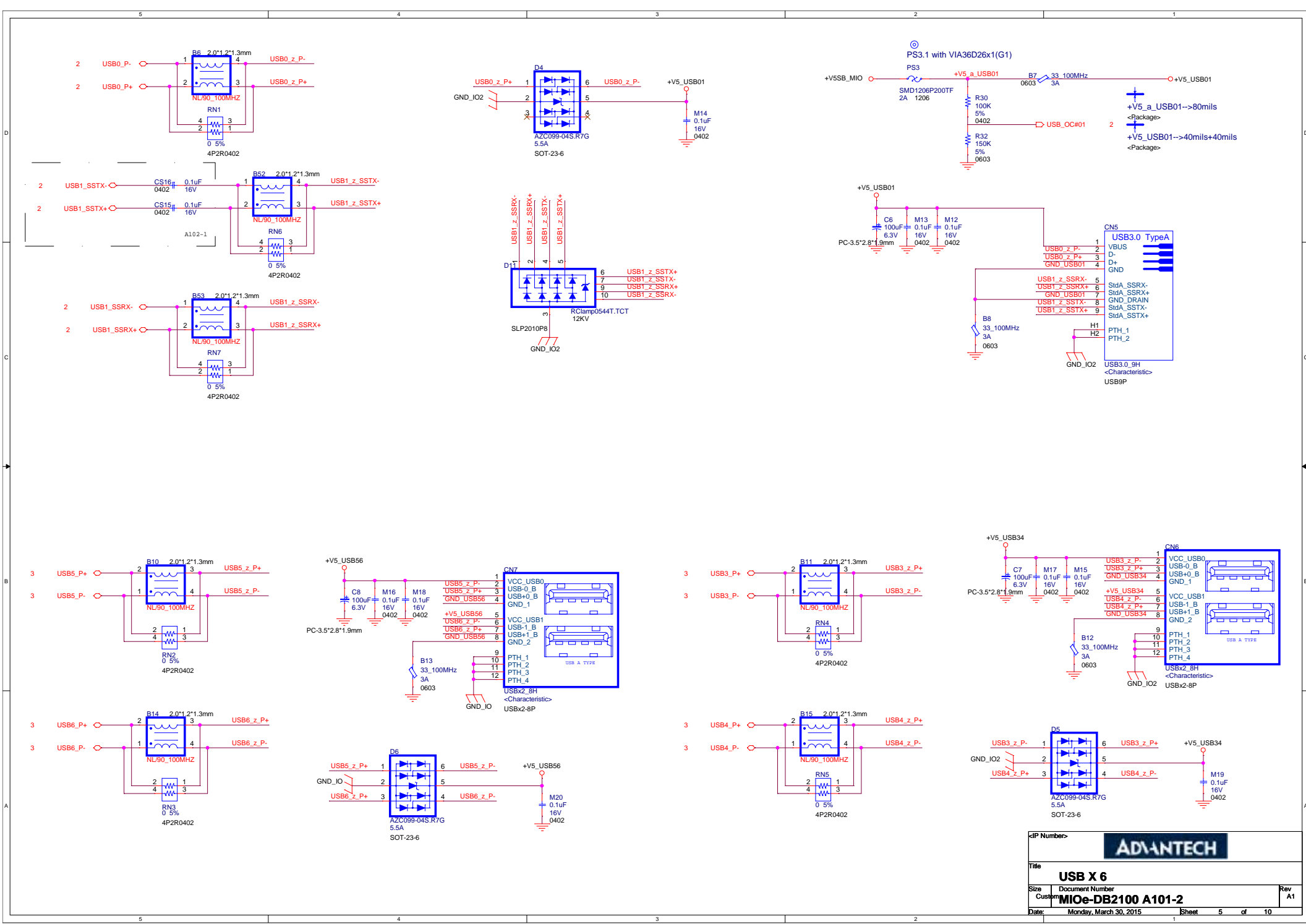

Title		USB X 6	
Size	Customer	Document Number	Rev
		MIOe-DB2100 A101-2	A1
Date:	Monday, March 30, 2015	Sheet	5 of 10

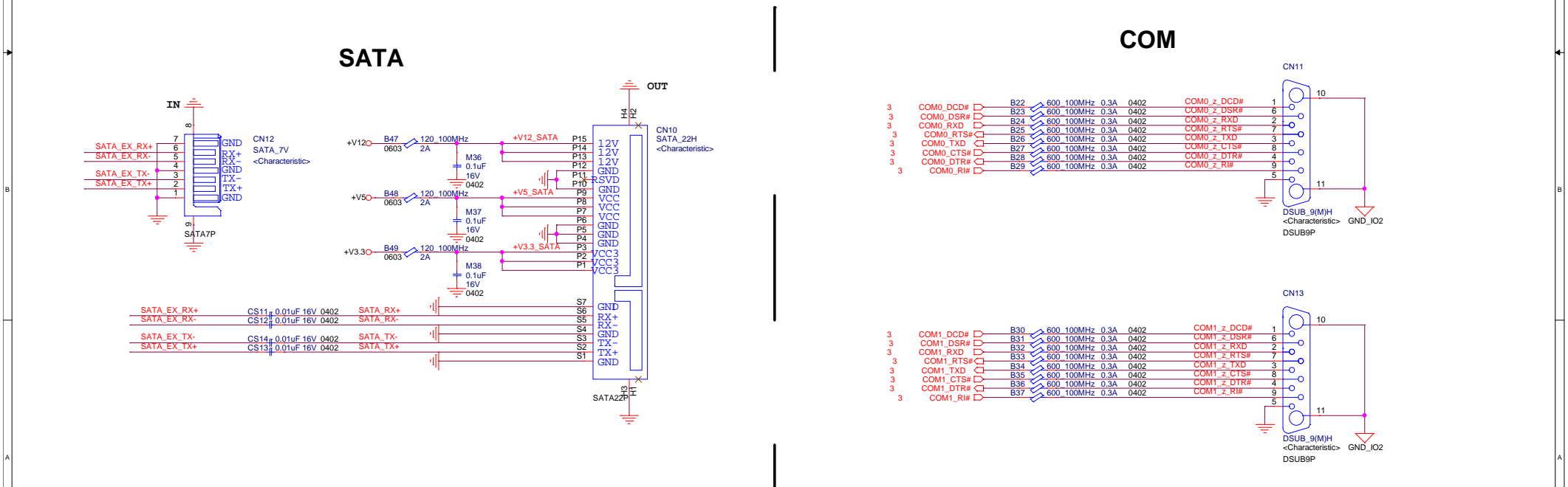
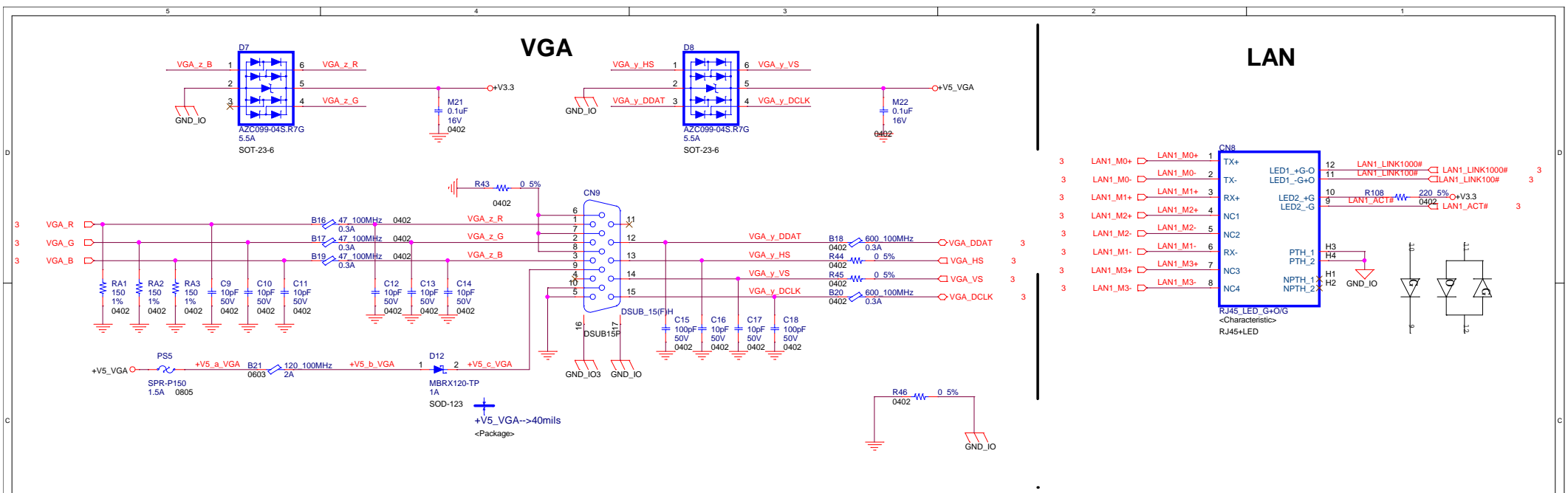

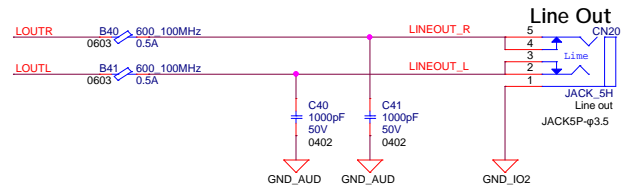
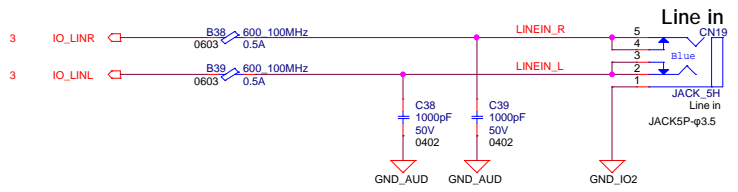
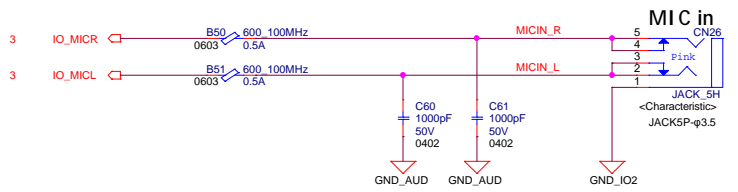

MIO	IO
3-5	1-3
4-6	2-4

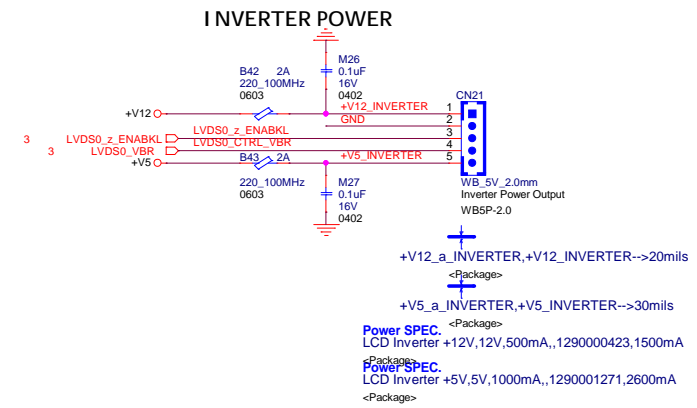
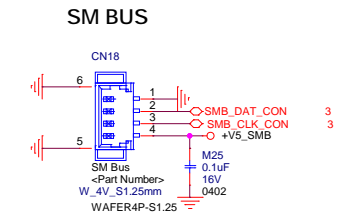
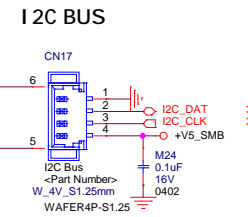
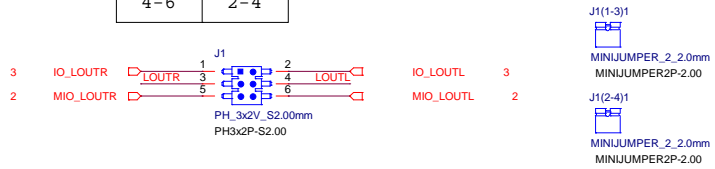

FOR LPC MODULE

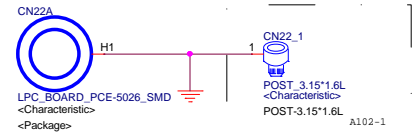
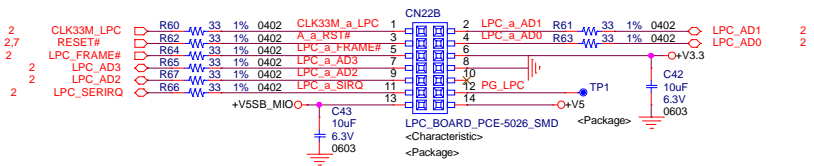

GPIO

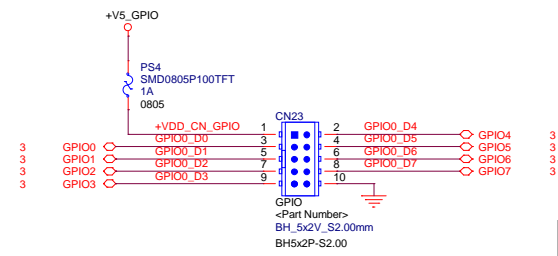

ADINTECH

Title: **Audio/LPC/GPIO/Other**

Size: **MIOe-DB2100 A102-2**

Date: **Monday, March 30, 2015** Sheet **8** of **10**

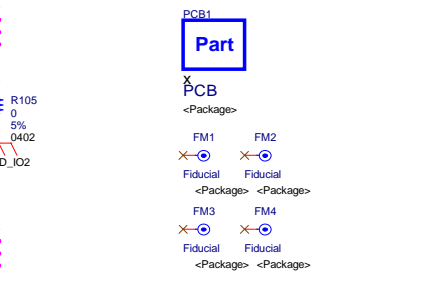
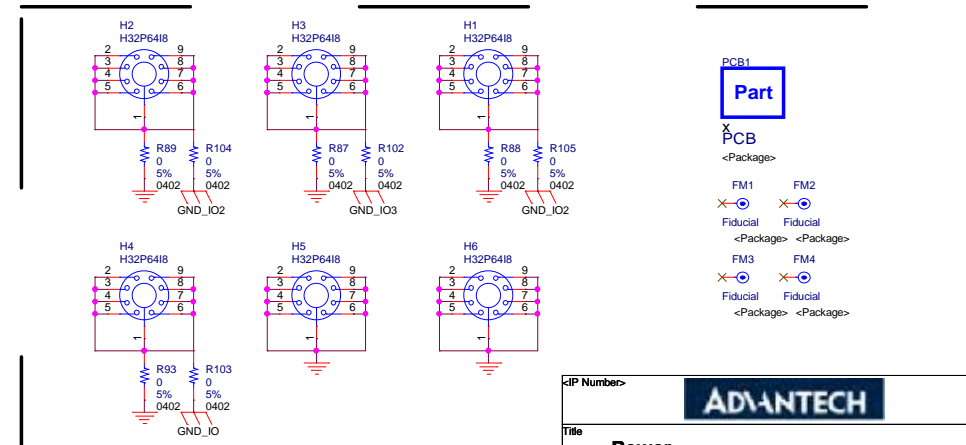
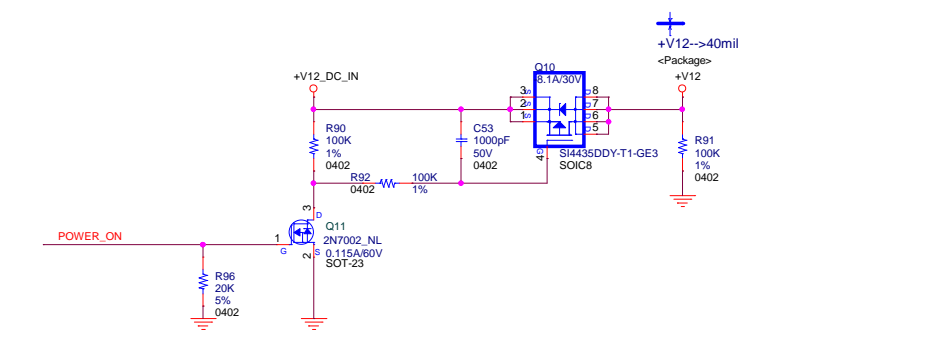
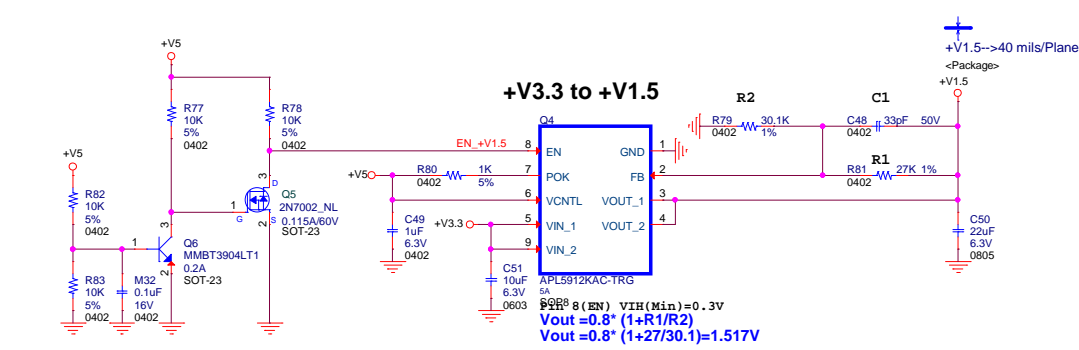
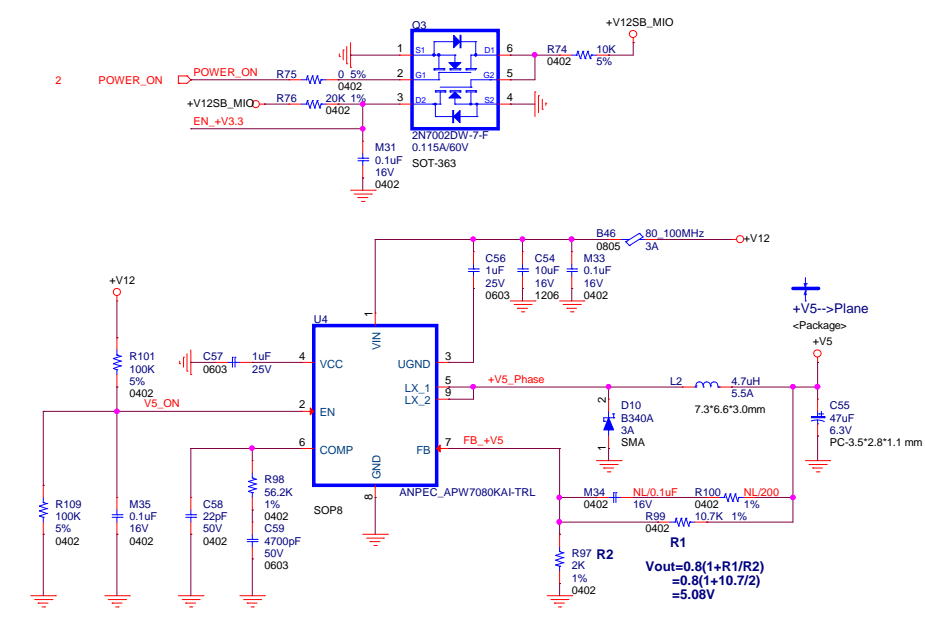
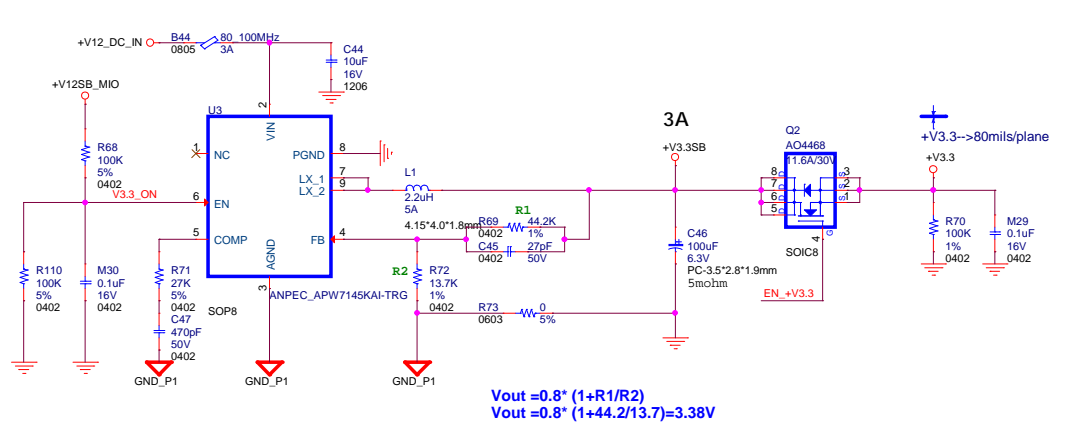
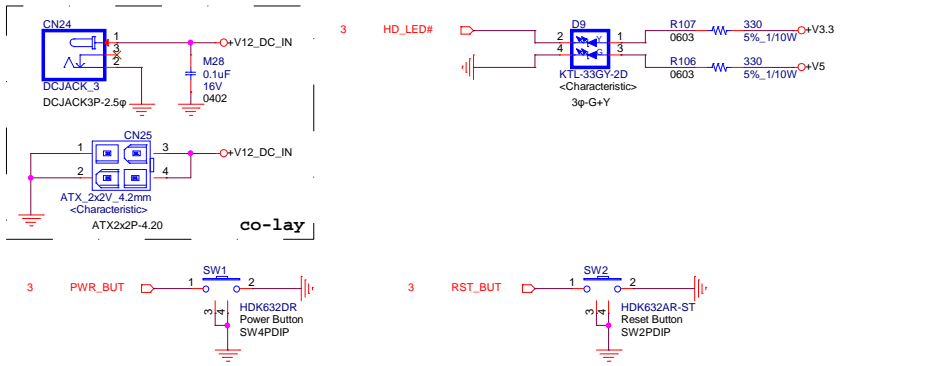

MIOe-DB2100 Revision History

MIOe-DB2100 REV.A101-1 PCB:19A6DB2100-01 96BOM:9696DB2100E Date: 2014/7/15

1. PCB: 19A6DB2100-01 PC:RD1200325001

MIOe-DB2100 REV.A101-2 PCB:19A6DB2101-01 96BOM:9696DB2100E Date: 2014/12/9

1. PCB: 19A6DB2101-01 PC:RD1200325001
2. PG05: Add Cs15.CS16 to correct USB3.0 waveform issue
3. PG08: Add CN22_1 for DFM

<IP Number>			
Title			
History			
Size	Document Number	Rev	
Custom	MIOe-DB2100 A101-2	A1	
Date:	Monday, March 30, 2015	Sheet	10 of 10